



BELGARD COMMERCIAL[®]

Commercial Site
Solutions Guide



TABLE OF CONTENTS

01

Interlocking Concrete Pavement Systems

Pages 4 - 15

- Designing the Pavement System
- Pattern Versatility
- Concrete or Asphalt Overlays
- Handling H-20/HS-20 Loading
- Ensuring Compliance & Public Safety
- Lower Capital & Maintenance Costs
- Improved Life Cycle

02

Permeable Interlocking Concrete Pavements (PICP)

Pages 16 - 27

- Stormwater Management
- Preventing Downstream Impacts
- Stormwater Quality
- Recommended Maintenance
- Handling Roof Water
- Manufactured Treatment Devices
- Stormwater Harvesting
- Urban Environment
- Optimizing Land Use
- SWM Pave

03

Segmental Retaining Walls (SRW)

Pages 28 - 35

- Types of Retaining Wall Construction
- Segmental Retaining Wall Best Practices Guide
- How Segmental Retaining Walls Help in Land Development
- Examples of Site Utilization

04

Rooftop Plaza Pavers & Accessories

Pages 36 - 39

- Services Provided
- Pedestal Slection
& Elevations

ACRONYM GLOSSARY

AASHTO	American Association of State Highway and Transportation Officials
ADA	Americans with Disabilities Act
ASCE	American Society of Civil Engineers
ASTM	American Society for Testing and Materials
BMP	Best Management Practice
CN	Curve Number
CSA	Canadian Standards Association
CSO	Combined Sewer Overflow
DCOF	Dynamic Coefficient of Friction
DGA	Dense-graded Aggregate
ESAL	Equivalent Single Axle Load
FHWA	Federal Highway Administration
FSW	Freestanding Wall
GRS-IBS	Geosynthetic Reinforced Soil - Integrated Bridge System
GSI	Green Stormwater Infrastructure
ICP	Interlocking Concrete Pavement
ICPI	Interlocking Concrete Pavement Institute
LCCA	Life Cycle Cost Analysis
LEED	Leadership in Energy and Environmental Design
LID	Low Impact Development
NCMA	National Concrete Masonry Association
OGA	Open-graded Aggregate
PICP	Permeable Interlocking Concrete Pavement
RCA	Recycled Concrete Aggregate
SCM	Stormwater Control Measure
SRI	Solar Reflectance Index
SRW	Segmental Retaining Wall
TMDL	Total Maximum Daily Limit
TI	Traffic Index
TP	Total Phosphorous
TSS	Total Suspended Solids
USEPA	United States Environmental Protection Agency

01

Interlocking Concrete Pavement Systems

Belgard® is a leader in the concrete paver industry. Through rigorous internal research and development, Belgard continually develops unique and innovative pavement solutions that meet or exceed ASTM standards and are available in an array of colors, finishes, shapes, and sizes to meet the design needs of any pedestrian or vehicular application. In addition, Belgard offers a variety of tools and services to ensure the success of every project, from downloadable CAD files, engineering service to life cycle costing.

Designing the Pavement System	6
Pattern Versatility	8
Concrete or Asphalt Overlays	10
Handling H-20/HS-20 Loading	11
Ensuring Compliance and Public Safety	12
Lower Capital and Maintenance Costs	14
Improved Life Cycle	15

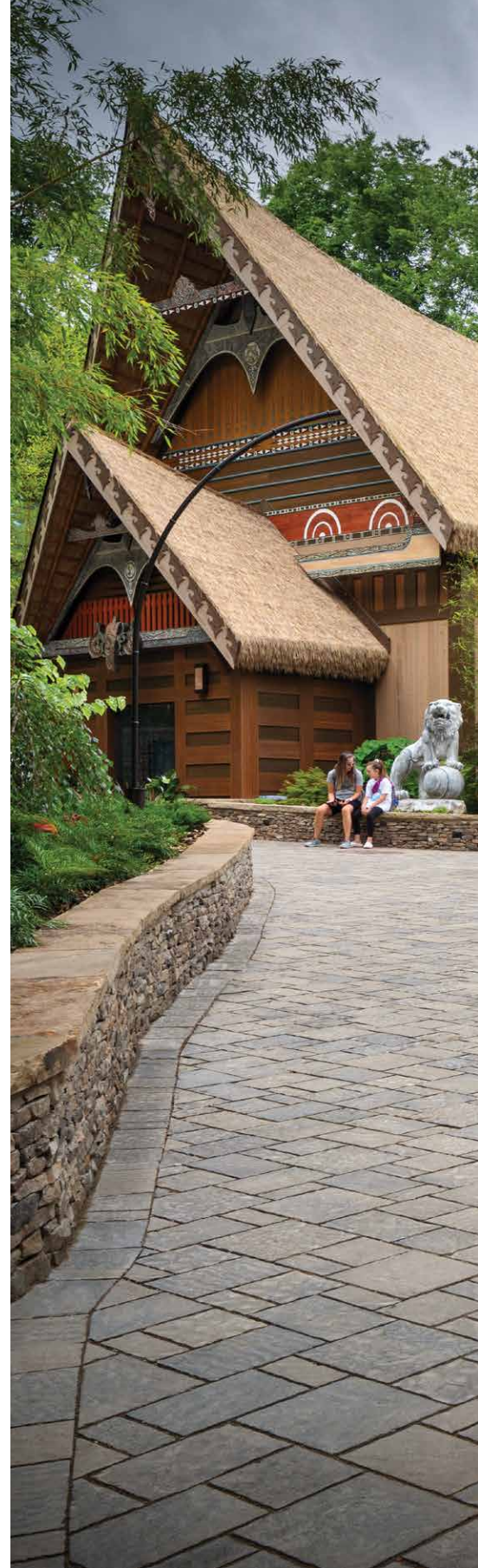



DESIGNING THE PAVEMENT SYSTEM

The Science Behind the Structural Design

Interlocking concrete pavement (ICP) systems, including permeable interlocking concrete pavement (PICP), are versatile and durable pavement systems which can be used for a variety of pedestrian and vehicular applications. The success of any pavement is dependent on proper design, construction, and maintenance. Fortunately, ASCE has published design standards for both ICP and PICP. ASCE 58-16 is the latest edition of the ICP standard for structural design, and ASCE 68-18 is the recently published standard for PICP for both structural and hydrologic design.

Designers can utilize these ASCE design standards to calculate the minimum pavement section to withstand the damage of repetitive dynamic loading from traffic over the pavement's

lifespan based on the native soil's bearing capacity. Equivalent single axle loads (ESALs) are used to determine the pavement damage done by each vehicle type compared to the damage caused by an 18,000-pound axle load. For example, passenger cars have a vehicle load factor of 0.0004 (it takes 2,500 cars to equal one ESAL) while a fully loaded fire truck can be as many as 10 ESALs.

Once the traffic loading is calculated, paver thickness and aspect ratio must be selected to maximize performance and durability. The heavier the expected traffic, the thicker the paver needs to be to prevent rotation. Key factors for design of both ICPs and PICPs are subgrade strength, thickness of the base materials, paver thickness, paver aspect ratio, and laying pattern.



For more information please contact your local Belgard Sales Representative

Is the Concrete Segmental Product a Paver, Slab or Plank?

Paver shape and thickness must be selected based on the application. Most long planks and large slabs are not suitable for vehicular applications. Concrete segmental units should be evaluated based on a variety of site-specific conditions. The project pavement engineer should confirm that the product can meet expected performance for vehicular loading conditions.

PRODUCT	AREA (SQ. IN.)	MINIMUM THICKNESS (IN)	MAXIMUM LENGTH OR WIDTH (IN)	ASPECT RATIO	PLAN RATIO	ASTM STANDARD	TYPICAL APPLICATION
Paver	≤101	2.4"	NA	≤4:1	NA	C936	PEDESTRIAN OR VEHICULAR
Slab	>101	1.2"	48	>4:1	NA	C1782	PEDESTRIAN
Plank	≤288	2.4"	48	≥4:1	≥4:1	N/A	PEDESTRIAN

NOTE: Reference the Canadian Standards Association A231.1 and A231.2 for unit concrete definitions applicable in Canada

Sample Aspect & Plan Ratios

	WIDTH	LENGTH	THICKNESS	ASPECT RATIO	PLAN RATIO
	6"	12"	60 mm (2 3/8")	5.1:1	2:1
			80 mm (3 1/8")	3.8:1	
			101.6 mm (4")	3:1	
	6"	6"	60 mm (2 3/8")	2.5:1	1:1
			80 mm (3 1/8")	1.9:1	
			101.6 mm (4")	1.5:1	
	6"	9"	60 mm (2 3/8")	3.8:1	1.5:1
			80 mm (3 1/8")	2.9:1	
	4"	24"	80 mm (3 1/8")	7.7:1	6:1

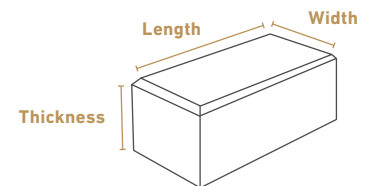





$$\text{Aspect Ratio} = \frac{\text{Length}}{\text{Thickness}}$$

$$\text{Plan Ratio} = \frac{\text{Length}}{\text{Width}}$$

Paver Application Recommendations

The following chart contains general recommendations for both interlocking and permeable concrete pavement systems including minimum thickness and maximum aspect ratio for several traffic types and uses. While this chart provides general recommendations, a pavement design professional should confirm that the product selected meets local standards and site-specific traffic and use conditions.

TRAFFIC TYPES	TYPICAL USES	TYPICAL LIFETIME DESIGN ESALS	TRAFFIC INDEX	MAXIMUM ASPECT RATIO	MINIMUM THICKNESS	ICP ¹	PICP ²	HEAVY VEHICLES ³ PER DAY
 Pedestrian	Pedestrian Commercial Plaza Residential Driveways	0 ≤ 10,000	0 5.2	N/A 4:1 or 5:1 ⁴	60 mm 60 mm	✓ ✓	✓ ✓	0 < 1
 Light Vehicles	Commercial/Business Parking Access Ways	≤ 30,000	5.9	4:1	80 mm	✓ ✓	✓ ✓	≤ 5
 Occasional Heavy Vehicles	Facility Parking Residential Roadways	≤ 90,000 ≤ 110,000	6.7 6.9	3:1 3:1	80 mm 80 mm	✓ ✓	✓ ✓	≤ 10 ≤ 10
 Frequent Heavy Vehicles	Local Roads Commercial Roads & Bus Parking Minor Collector Major Collector Arterial	≤ 330,000 ≤ 500,000 ≤ 1,000,000 ≤ 5,000,000 ≤ 9,000,000	7.8 8.3 9.0 10.2 11.6	3:1 3:1 3:1 3:1 3:1	80 mm 80 mm ⁵ 80 mm ⁵ 101.6 mm 101.6 mm	✓ ✓ ✓ ✓ ✓	✓ ✓ ✓ ✓ ✓	>10 >10 >10 >10 >10

1. Consult ASCE 58-16 Structural Design of Interlocking Concrete Pavement for Municipal Streets and Roadways for ICP design guidance.
2. Consult ASCE 68-18 Permeable Interlocking Concrete Pavement for PICP design guidance.
3. Heavy vehicles are defined as any vehicle larger than a single unit truck as defined by AASHTO.
4. Areas subject to occasional maintenance or emergency vehicles shall have a maximum aspect ratio of 4:1 for 60 mm pavers and 5:1 for 80 mm pavers.
5. Projects with high volumes of heavy vehicles should consider using 101.6 mm pavers.
6. Concrete grid pavers can be used in parking lot and emergency access ways up to a maximum of 7,500 lifetime ESALs and a maximum of ≤ 2 heavy vehicles per day. (Aspect ratio is not applicable for grid pavers)
7. The above chart is for general guidance. When selecting pavers for site-specific conditions, please consult your local Belgard Sales representative for assistance.



Pedestrian

Designated for areas that are pedestrian only, or commercial plazas that may require occasional access for emergency or maintenance vehicles, as well as residential driveways.



Light Vehicles

Designated for commercial vehicular areas, access ways, and parking lots where only cars and light trucks are anticipated. Heavy vehicles should have limited access and use.



Occasional Heavy Vehicles

Designated for vehicular areas, parking lots, and roadways where limited heavy vehicles are anticipated daily such as large delivery trucks or garbage trucks.



Frequent Heavy Vehicles

Designated for vehicular areas, parking lots, and roadways where heavy vehicles are a regular component of the daily traffic volume.

PATTERN VERSATILITY

Belgard Pavers

Belgard's collection of pavers create the ultimate in pattern versatility. Add to this the various aesthetic elements (including colors and textures) that are available to create unique patterns, accents, highlights and borders and the possibilities are truly endless. For pedestrian applications, the pattern options are practically limitless. However, for vehicular applications we recommend 45 or 90 degree herringbone laying pattern to ensure maximum performance for high ESAL applications.

The following are examples of some popular paver patterns:

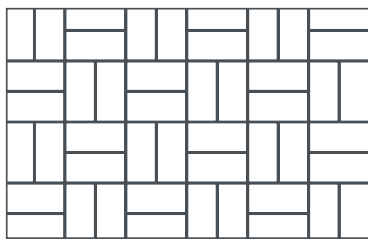

BASKET WEAVE

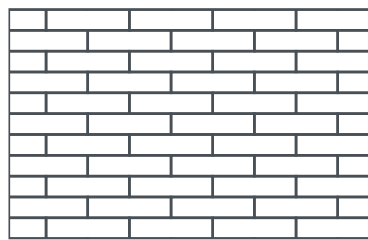

RUNNING BOND

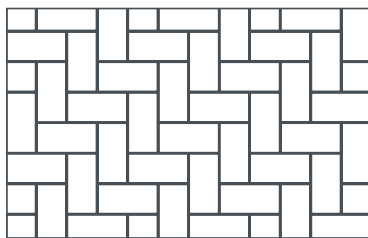

HERRINGBONE

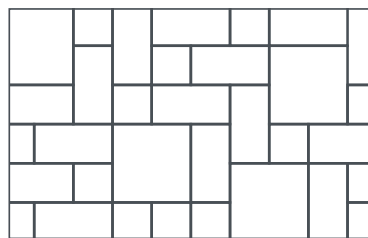

ASHLAR



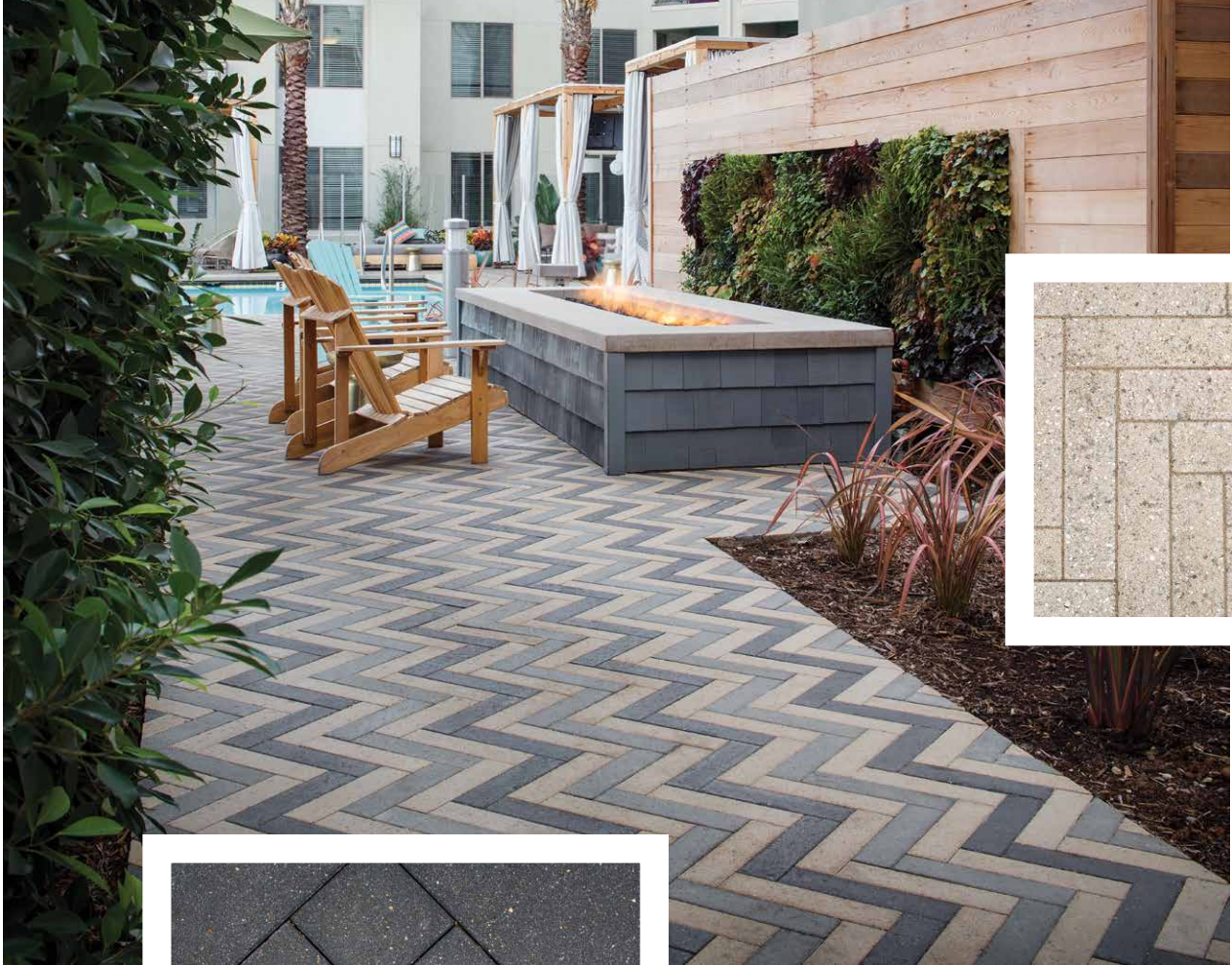

CONCRETE & ASPHALT OVERLAY

When installing pavers over the top of an existing asphalt or concrete pad, there are three installation options.

1. Sand Set

In a sand set application, a 1" sand bedding layer is placed between the pavers and underlying asphalt or concrete (similar to a standard installation). Drain holes are required at low spots to allow water that seeps into the joints to escape.

This method is most common in pedestrian applications, although it can be applied in vehicular applications as long as suitable curb & durable bedding sand is used.

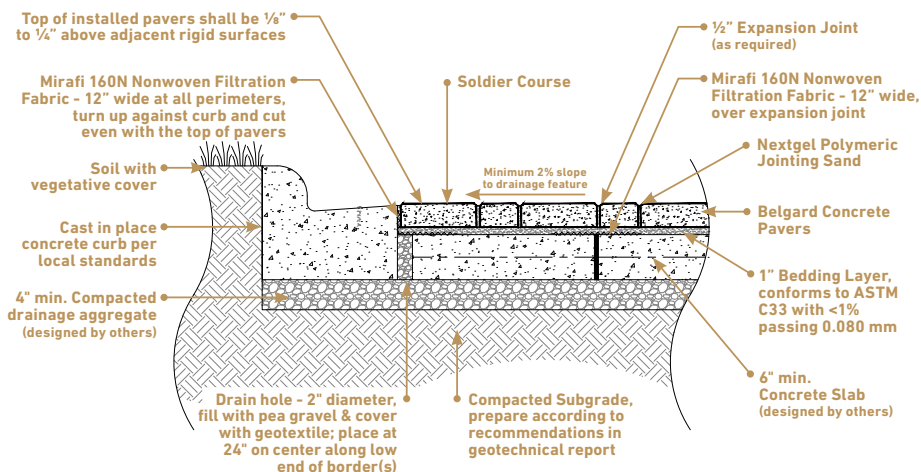

2. Bituminous Set

This is similar to sand set except a bituminous binder is added to the bedding sand which, in essence, adheres the pavers to the underlying concrete (pedestrian or vehicular applications) or asphalt (pedestrian applications only).

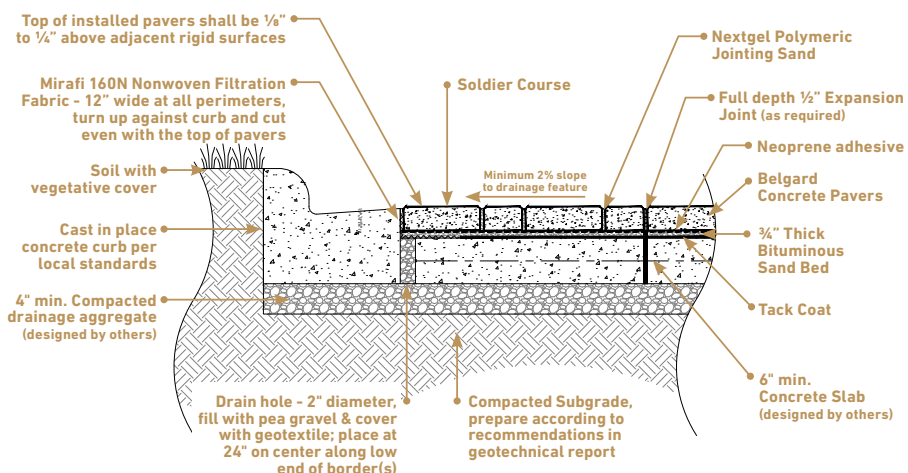

3. Mortar Set

A mortar set approach is an adhered design solution that bonds the pavers to a concrete base. It is typically used for non-vehicular applications. Latex modified mortar is recommended over traditional cement sand mortars. This assembly should be used with design input from the mortar supplier.

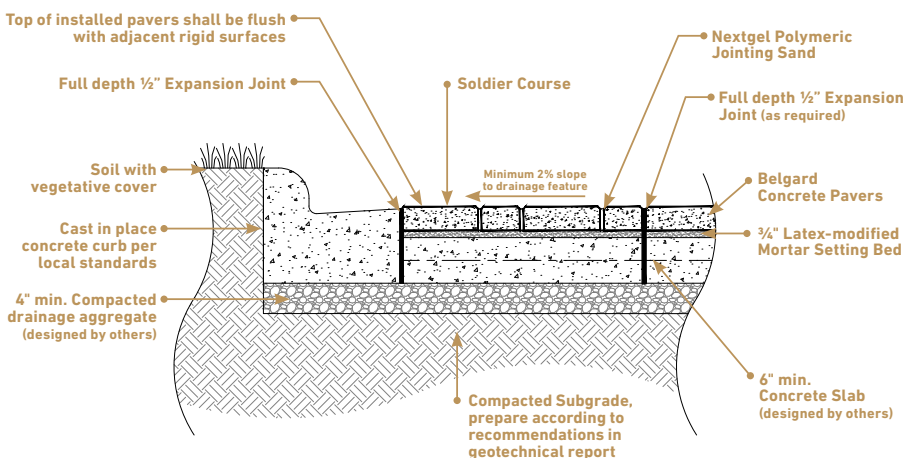

HANDLING H-20/HS-20 LOADING

AASHTO's H-20 and HS-20 are live load ratings applied to the design of bridges or other suspended items (e.g. lids for concrete vaults).

H-20 Loading

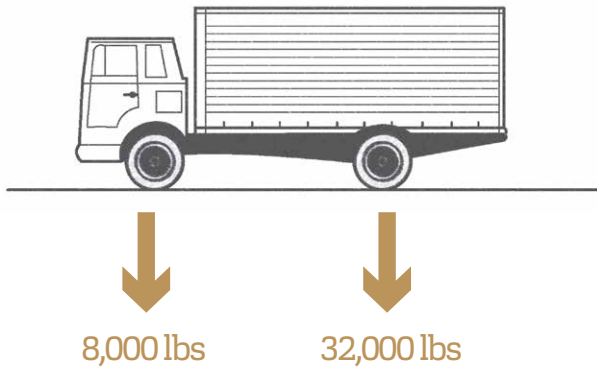

HS-20 Loading

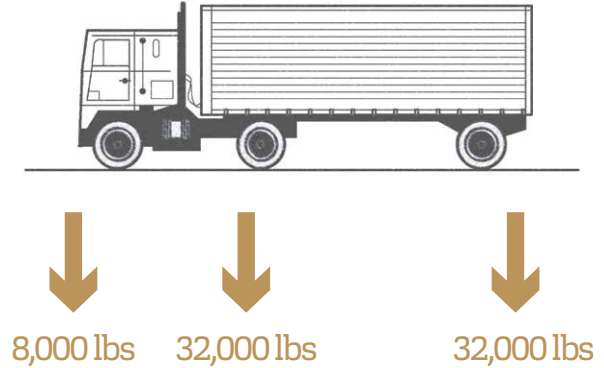

Because the pavers sit on a flat aggregate surface, they are not subject to the same bending moments and shear, and therefore will not collapse under the applied loads. Paver systems are actually designed for thousands, if not millions, of ESAL, which represent the estimated number of vehicles that pass over the surface during the design life.

See “Designing the Pavement System” on page 6 for more details

In terms of being able to withstand the surface pressure exerted by the truck tires, the heaviest gross axle weight (GAW) for a firetruck that is allowed is 24,000 pounds. Assuming standard tires are used (even though Super Single tires are required) the maximum weight on each of the wheels is 12,000 pounds (24,000 pounds/2 wheels). Using a conservative contact area on the bottom of the wheel of 8 inches square, the pressure exerted by each front wheel is 187.5 psi (12,000 pounds/64 square inches). Any concrete paver offered under the Belgard line is made in accordance with ASTM C936, which calls for an average compressive strength of 8,000 psi with no individual unit being less than 7,200 psi. Simply put, Belgard pavers are on average 40 times stronger than required to withstand the surface pressure that would be exerted under the most extreme conditions, and therefore exceed the requirements of H-20 and HS-20 loading if the pavement has been properly designed for the site conditions including traffic loading and subgrade strength.



ENSURING COMPLIANCE & PUBLIC SAFETY

The 2010 ADA Accessibility Guidelines provide design requirements for accessibility to buildings and site by individuals with disabilities. The following sections address how Belgard® pavers and slabs can be used to meet ADA guidelines.

Section 302.1

Floor and ground surfaces shall be stable, firm and slip resistant.

Pavers and slabs installed on aggregate or concrete base assemblies inherently create stable and firm surfaces. Slip resistance can be measured using ANSI A326.3 American National Standard Test Method for Measuring Dynamic Coefficient of Friction of Hard Surface Materials, which covers all hard flooring surfaces, interior and exterior. The test method uses a tribometer BOT 3000E device. Belgard smooth finish pavers meet the acceptance criteria of ≥ 0.42 .



**BOT-3000 Universal Walkway Tester
Digital Tribometer**

**Typical Belgard Paver
DCOF wet values 0.6 to 0.75**

Section 302.3

Openings in floor and ground surfaces shall not allow passage of a sphere more than 1/2 inch (13 mm) diameter.

To verify the openings in a ground surface are compliant, a simple test is done to see if a 1/2 inch diameter sphere can pass through the opening. Most Belgard permeable pavers create surface openings less than 1/2 inch wide. The optimal opening size for permeable joint aggregates is 3/8" (10 mm) which is below the ADA opening threshold.



The following icon is used on the website and in the product information pages in company catalogs to identify products that can be utilized to construct an ADA compliant pavement.

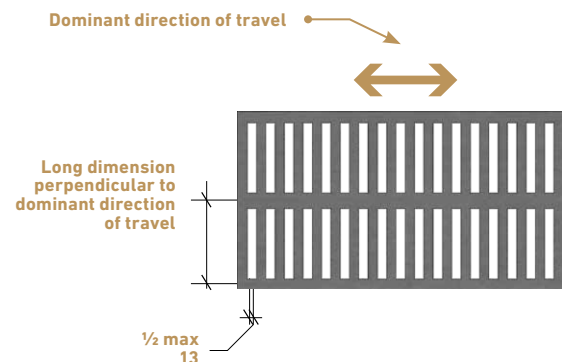

Section 303.2

Changes in level of 1/4 inch (6.4 mm) high maximum shall be permitted to be vertical.

Pavers, when installed correctly, are placed on a loose layer of bedding aggregate, then compacted down into it to set the pavers into place. One purpose of the bedding layer is to adjust for possible height variances in the paver thickness so that the final surface does not have any changes in elevation present. Belgard and industry paver surface construction tolerances are +/- 1/8 inch (3.2 mm), which is more stringent than the ADA lippage threshold.

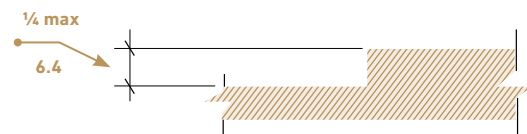
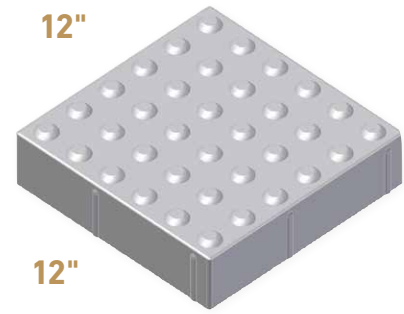

**Figure 303.2
Vertical Change in Level**

Section 705

Detectable warnings shall consist of truncated domes and shall comply with 705.

Belgard truncated dome pavers are manufactured in accordance with the dome size and spacing requirements in Section 705.



Detectable warning surfaces shall contrast visually with adjacent walking surfaces either light-on-dark or dark-on-light.

Light Reflectance Value (LRV) testing was done on select Belgard paver colors to determine which pairings provide the required visual contrast. The test results are summarized in the adjacent table.

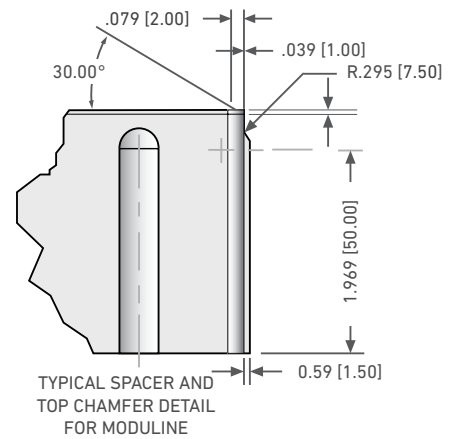

LRV FOR BELGARD COLORS	
COLOR	LRV
Foundry	20.5
Graphite	9.8
Linen	30.4

Wheelchair User Comfort

Although not addressed in the ADA Accessibility Guidelines, there has been industry research regarding pavement roughness and wheelchair use comfort. 2018 research found that pavers with micro-chamfers (nominal 3 mm width) and industry recommended joint widths, along with smooth or low-profiled textured pavers did not cause wheelchair discomfort.

Most Belgard pavers, slabs and planks can be used in pedestrian wheelchair access applications.



LOWER CAPITAL & MAINTENANCE COST

Machine Installation

The standard pre-conception for pavers is that they are expensive. This, for a large part, is due to the need for labor to hand install individual units. Belgard has various pavers that are manufactured in machine installation patterns, whereby specialized equipment can install upwards of 5,000 square feet in a single work day.

This automation of the installation process significantly reduces the capital costs. Entire parking lots, streets, ports & airport tarmacs have been economically constructed using this approach.

The fact that pavers are factory manufactured in accordance with ASTM C-936 “Standard Specifications for Solid Interlocking Concrete Paving Units” also benefits the bottom line. Test reports can accompany the product when it is shipped onsite, eliminating the potential risk of having to replace the product due to poor quality. Once the jointing material is installed, the surface is immediately ready for traffic — no curing delays are required.



Paver laying machine

Access of Underground Utilities

The annual cost of utility cuts in the average city is in the millions of dollars. The existing surface material needs to be broken out and disposed of, the underground repairs made, and then new material used for the final patch. With each patch, the service life of the pavement is also reduced.

With interlocking concrete pavements, the short term costs and long term impacts are both reduced. Clusters of pavers can be removed by hand— saw-cutting equipment and pneumatic jack-hammers are not required. The same pavers can also be reinstated, reducing the waste disposal and replacement material costs. Short term patching products are eliminated, and there are no changes to the area’s overall appearance. Being a flexible pavement system with built in control joints, the pavement also has an increased ability to deal with any subsequent fill settlement.



The following icon is used on the website and in the product information pages in company catalogs to identify mechanical installation capabilities.



Pavers being removed to allow for an underground repair.

IMPROVED LIFE CYCLE

Longer Service Life, Less Maintenance, Greater Value

An investment in roadway infrastructure does not stop after initial construction. Like any asset, it requires some investment to keep it in usable condition. For roadways, this includes ongoing surface maintenance, periodic restoration and eventual base rehabilitation.

Life cycle cost analysis is a technique that quantifies all of the costs associated with the construction and maintenance of a pavement over a set analysis period. According to the report “Life Cycle Cost Management of Interlocking Concrete Block Pavements – Methodology Report” from ARA/ICPI, a paver system is expected to last 30 or more years before it reaches the trigger pavement condition index where rehabilitation is required. During this time, the following level of maintenance is expected.

At years 8 and 28, it is expected that approximately 2% of the pavers over the entire surface will have become cracked or chipped and will need to be replaced. In years 20 and 35, a more significant maintenance is expected to take place— this includes removal of a larger area of pavers (most likely in the wheelpaths), leveling/replacement of the bedding sand underneath, then reinstatement of a majority of the original pavers.

When compared to the equivalent life cycle costing of other traditional paving practices, the results for paver systems are often better because of the:

1. **Higher performance life of pavers as compared to asphalt.**
2. **Lower capital cost of pavers compared to cast-in place concrete**
3. **Lower/easier maintenance requirements**
4. **Reduced vulnerability to utility cuts**

Although we cannot guarantee the life cycle costing will be less in every circumstance, we are willing to assist with the analysis to determine if pavers are ultimately more economical. Contact your local Belgard Representative for details.

“Paver installations have demonstrated life spans that exceed 30 years, as compared to traditional pavement which typically lasts 12-15 years”

YEAR	ACTIVITY	QUANTITY (%)
8	Replace Cracked Pavers	2
20	Replace Worn/Rutted Pavers (wheelpath)	5
28	Replace Cracked Pavers	2
35	Replace Worn/Rutted Pavers (wheelpath)	5

Sample Range of Results of Life Cycle Analysis

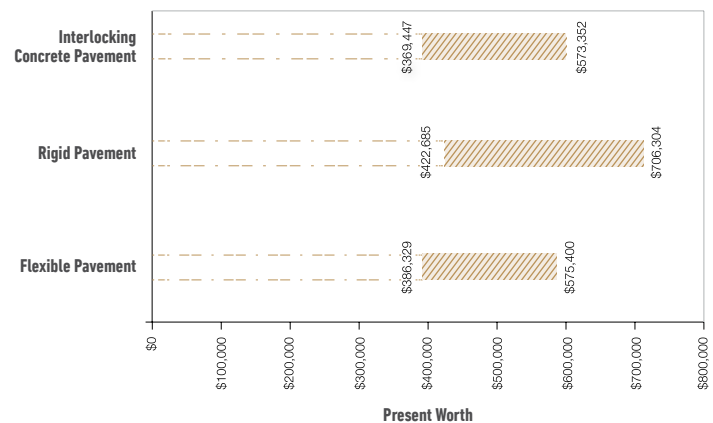

02

Permeable Interlocking Concrete Pavements (PICP)

Use of PICP on various pedestrian and vehicular applications can add to the aesthetic look of a project, eliminate the need for traditional stormwater conveyance works, improve groundwater quality, and increase usable land space by decreasing or eliminating the need for a retention pond. Belgard experts can work closely with your design team to design and gain approval for the PICP system that best matches the onsite soil conditions, design storms, and local regulatory requirements.

Stormwater Management	18
Preventing Downstream Impacts	19
Stormwater Quality	20
Recommended Maintenance	20
Handling Roof Water	21
Manufactured Treatment Devices	22
Stormwater Harvesting	23
Urban Environment	24
Optimizing Land Use	25
SWM Pave	26

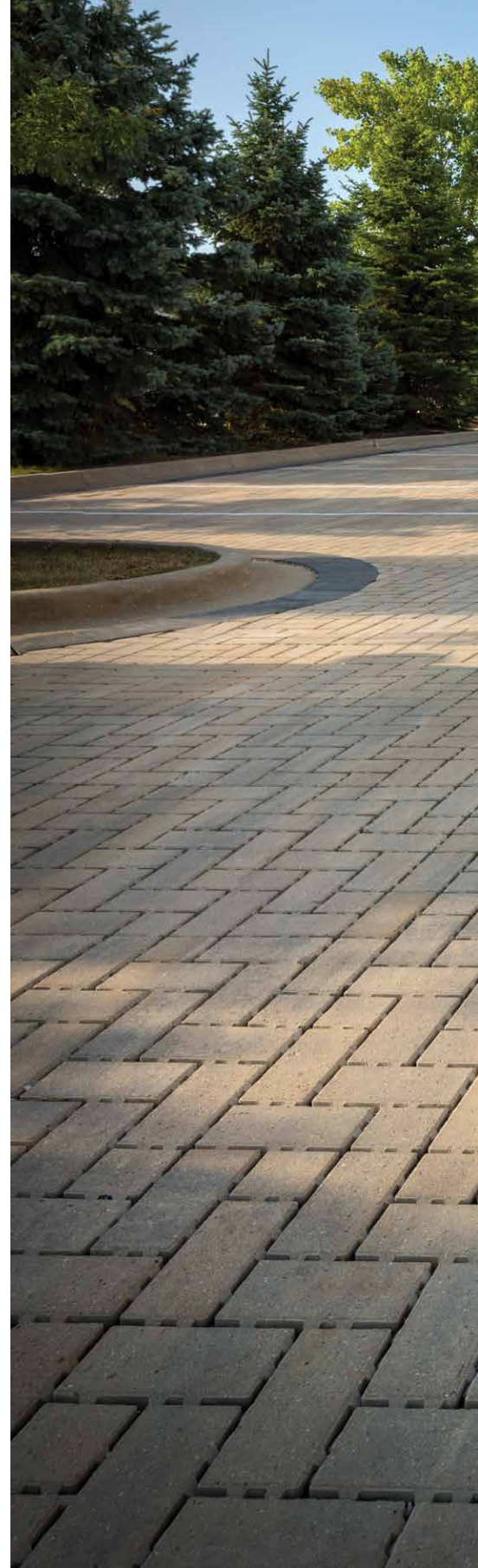

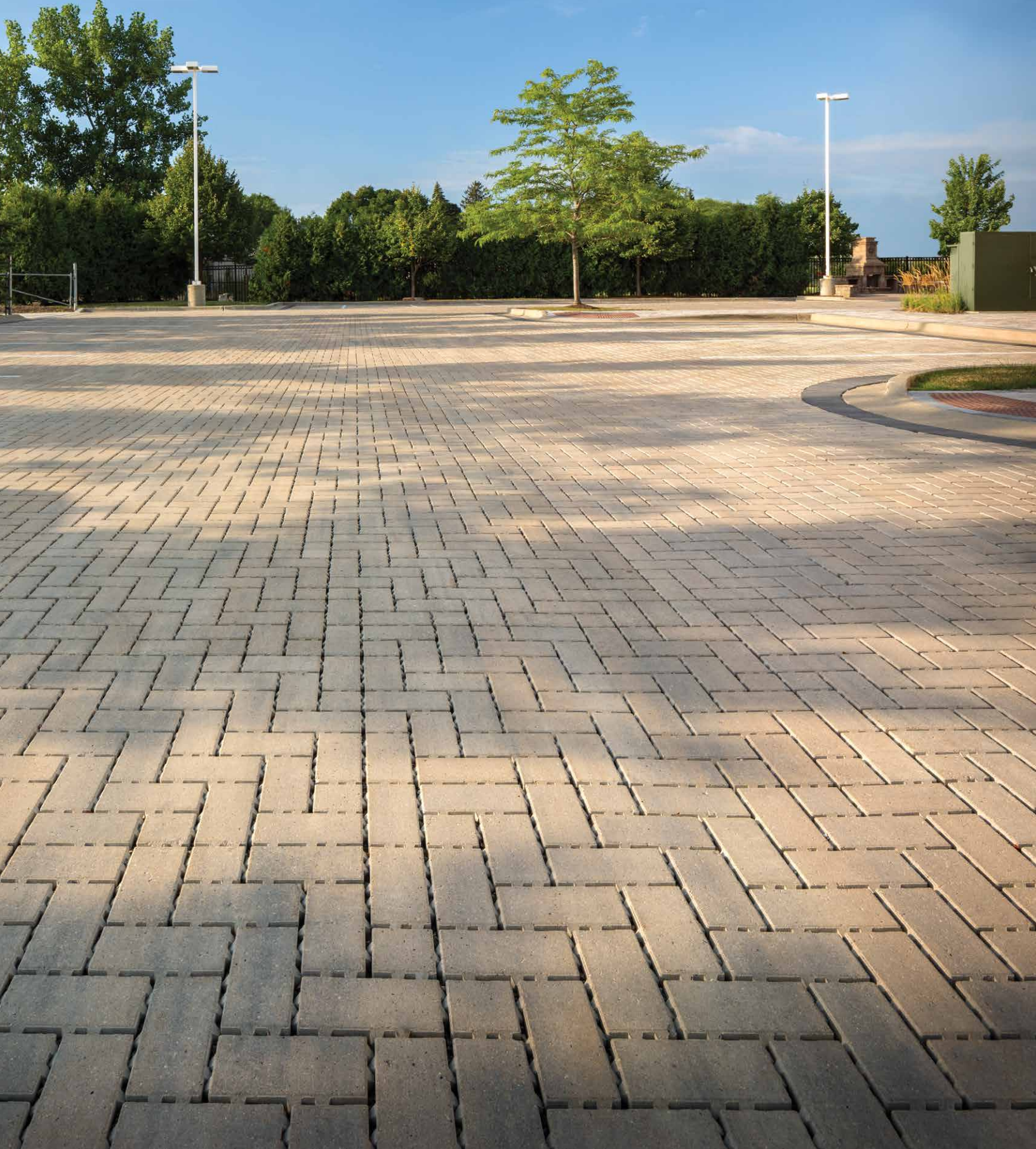

STORMWATER MANAGEMENT

PICP Multi-functionality

The cornerstone of sustainability and green infrastructure is multi-functionality. In conventional infrastructure systems, every component has one job to perform. For example, asphalt provides the driving surface, inlets collect the runoff from the pavement, pipes carry the water away, detention ponds store water to reduce the peak flow, and water quality BMPs cleanse the water before it is released into the river. Permeable Interlocking Concrete Pavements (PICP) provide these five functions in one system: 1) The pavers provide a heavy-duty driving surface; 2) The entire paver area captures stormwater; 3) The aggregate filled joints filter out sediment; 4) The open-graded aggregates below the pavers convey water downstream; 5) The voids in the aggregates (approx. 40%) provide storage.

By utilizing the multi-functionality of PICP systems, expensive infrastructure components, including inlets, pipes, water quality devices, and detention ponds, can be eliminated creating additional space for development and lowering overall stormwater management costs. Permeable pavers also last twice as long as conventional pavements and cost less to maintain.

Hydrologic Design of PICP

The hydrologic design will typically govern the final configuration of the system. The most common design methodologies used are event-based hydrograph estimations or continuous simulation modeling. The most common event-based estimation method is the Watershed Hydrology Program (WinTR-20). The most common continuous simulation models are the US EPA Stormwater Management Model (SWMM) and the Hydrologic Engineering Center Hydrologic Modeling System (HEC-HMS).

These methodologies rely on developing a Curve Number (CN), which is an empirical parameter related to the runoff response of a watershed. Because PICP can improve the hydrologic function of a developed area, a reduced CN is used. ASCE 68-18 provides a means for calculating the reduced CN accounting for the storage in the system and infiltration into the soil. The reduced CN is typically slightly greater than or equal to the pre-developed CN.

The Rational Method is not generally used for designing PICP systems, but in some cases regulatory agencies require it. When using the Rational Method, a C-value, which represents the percentage of rainfall that becomes runoff, can be calculated for a PICP system by dividing the total calculated outflow by the total calculated inflow. Typical calculated C-values range between 0.25 to 0.40 depending on the design of the system.

Slope affects the design of the system and once the surface slope exceeds 0.5% flow dams should be considered. The detail below shows how flow dams can be used to increase the efficiency of the system to store and manage stormwater. The flow dams have orifices cut into them and the top of the flow dam is a weir allowing each storage cell created to be modelled as detention basins in series. The lowest storage cell can be connected to an outlet control structure used to attenuate peak flows and meet the allowable release rate of the regulatory agency.

Credit for Pervious Surface

Correctly designed, installed, and maintained, PICP systems have surface infiltration rates higher than that of almost any natural soil, and several times greater than the maximum possible rainfall intensity. This is why a PICP surface should be given complete credit for "100% perviousness," as would a meadow or forest.

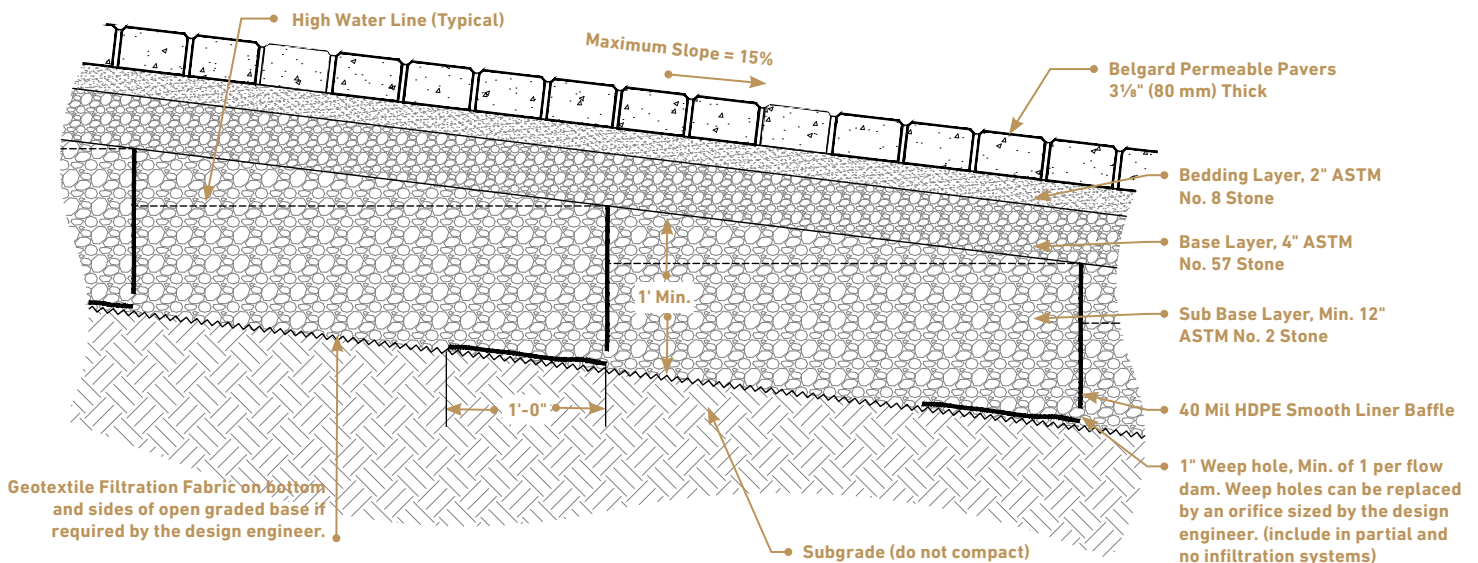

PREVENTING DOWNSTREAM IMPACTS

Erosion Control

Improperly managed stormwater can result in downstream hydrologic impacts, such as erosion along existing drainage courses, flooding of adjacent low lying areas, and sedimentation/contamination of receiving waters (including ecological areas such as wetlands and estuaries, recreational areas such as lakes and rivers, and/or surface water supplies of drinking water).

These impacts can be minimized, if not effectively avoided, through better site design using PICPs. Studies have shown that “the slower and more controlled outflow (from PICP) closely mimics natural interflow and reduces the risk of flooding and erosion in downstream receiving waters”.

Source: Drake, Jennifer and Tim Van Seters. "Evaluation of Permeable Pavements in Cold Climates" Toronto and Region Conservation Authority (TRCA), December 2012.



Reduced Thermal Impacts on Receiving Waters

Under predevelopment conditions, stormwater that infiltrates into the ground stays at a relatively constant temperature; conversely, post development stormwater runoff from impervious areas can be very hot in the summer months and extremely cold in the winter months. These temperature extremes can have a devastating effect on aquatic organisms. Many fish species can be harmed by acute temperature changes of only a few degrees. That is why the Independence & Security Act (2007) requires that predevelopment temperatures be maintained from all Federal development or redevelopment.

With PICP systems, the water is stored below ground, so the thermal temperature impacts are minimal.

Studies conducted at North Carolina State University verified that both warm and cold thermal buffering were provided by shallow infiltration systems like PICP, therein reducing the frequency of harmful temperatures.

Source: Wardynski, B.J., R.J. Winston, W.F. Hunt. 2012. "Thermal Mitigation Potential of Permeable Pavements", LID Research Summit.



STORMWATER QUALITY

PICPs are recognized by several agencies, including the US EPA, as providing stormwater quality improvements. Reported removal efficiencies for **Total Suspended Solids (TSS)**, **Total Phosphorus (TP)** and **Total Nitrogen (TN)** from different states are listed on the adjacent table.

PICP reduces pollutant concentrations through several processes including adsorption, microbial action, volatilization and filtration. Contaminants within the subgrade infiltrate will undergo further bacterial and chemical reactions with the native soils prior to reaching the groundwater table or receiving waters.

Filtration is not only effective at removing large particulate and suspended solids, but potentially also metals, Total Phosphorous (TP), and hydrocarbons subject to the degree that each binds (adsorbs) to the filtered particulates. Within the open graded base/subbase, it is expected that volatilization and microbial action in addition to adsorption, is taking place with some pollutants.

	TOTAL SUSPENDED SOLIDS	TOTAL PHOSPHORUS	TOTAL NITROGEN
Georgia	80%	50%	50%
New Jersey	80%	-	-
New York	82 - 95%	65%	80 - 85%
North Carolina	84%	30 - 84%	30 - 84%
Pennsylvania	85%	85%	30%
Texas (TCEQ)	89%	-	-
Virginia	-	25%	25%

RECOMMENDED MAINTENANCE

Studies have found a relationship between joint infill material and long term infiltration rates. ASTM No. 8, 89, or 9 stone in properly sized joint openings provide the best performance.

The joints of the PICP system, like any other filter, can become clogged. The FGCU study estimated it would take 7-20 years for a typical system to deteriorate to the point were it is no longer functional (infiltration rate less than 10 inches per hour), with the range being subject to the contaminant loading rate and the size of the jointing material used. Where contaminant loading is concentrated, such as around tree canopies, winter snow storage piles or stormwater run-on areas (water is running onto the PICP surface from adjacent areas), clogging can be accelerated.



The recommended regular maintenance includes semi-annual cleaning (spring and fall) using a mechanical or regenerative air sweeper to remove any surface debris, especially compostables like leaves and winter sand. Annual infiltration testing following ASTM C1781 should also be done on the PICP surface, especially at the previously listed spots. Where the infiltration rate is found to be approaching 10 inches per hour, or where there is any surface ponding noted, restorative maintenance using a vacuum truck should be conducted. Vacuum trucks are capable of extracting

the accumulated debris and jointing material from between the pavers. New jointing material is then swept back in, and the system is almost as good as new. Please note that power washing is not recommended as this will only push debris deeper into the joints.

To allow for replacement of pavers that may become damaged, and to ensure an even match with existing, a rule of thumb is to store 2 to 5% of the total project as attic stock. Damaged pavers can be pulled up and the new ones reinstated with a few simple tools.



Regenerative Air Sweeper for Regular Maintenance.



Vacuum Truck for Restorative Maintenance.

HANDLING ROOF WATER

In some locations, roof water can be managed by the PICP system if the system is designed to accommodate the additional water volume. When discharging roof water onto the PICP surface, the water is filtered the same as any direct rainfall, but the run-on area may be subject to accelerated clogging. Large roof drains may require flow dissipation to prevent washout of the jointing

aggregates. When roof water is diverted into the subbase, FloGard +Plus® Downspout Filters can be used to pre-treat the roof water and a catch basin can be used to dissipate the energy of the falling water. Surface water can also be collected using FloGard +Plus® Catch Basin Insert Filters to pre-treat runoff that enters the catch basin. The illustration below depicts both scenarios.

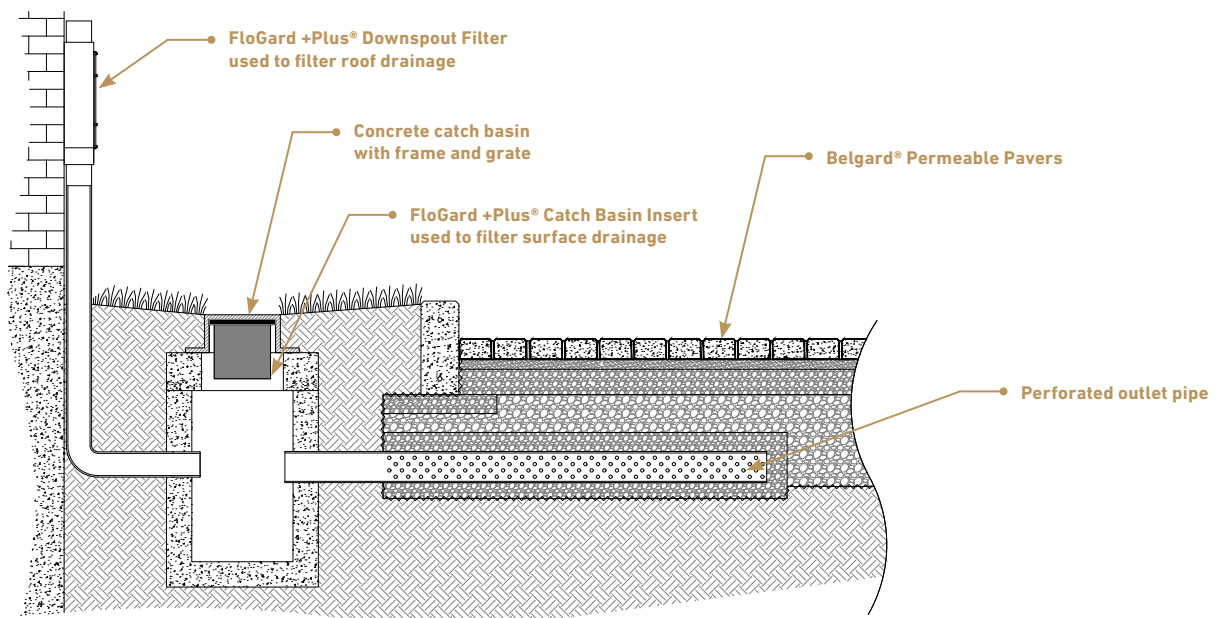

MANUFACTURED TREATMENT DEVICES

Complementary LID Solutions

Many jurisdictions now prefer Low-Impact Development (LID) solutions as the first choice to manage stormwater runoff. In addition to Permeable Interlocking Concrete Pavements (PICP), Oldcastle offers other LID Solutions to meet a variety of site constraints. These systems can be used as stand-alone treatment or in conjunction with PICP.



BioPod systems utilize an advanced biofiltration design for filtration, sorption and biological uptake to remove Total Suspended Solids (TSS), dissolved metals, nutrients, gross solids, trash and debris as well as petroleum hydrocarbons from storm water runoff. Environmentally friendly and aesthetically pleasing, BioPod systems are a proven, Low-Impact Development (LID) solution for storm water treatment. BioPod systems integrate seamlessly into standard site drainage and can accommodate a wide variety of vegetation to meet green infrastructure requirements.



TerraMod® Modular Bioretention System is a modular precast concrete bioretention cell system that uses soil-based filtration to remove sediment, metals, nutrients, petroleum hydrocarbons, gross solids and trash from stormwater runoff. BioMod systems can incorporate non-proprietary, low flow rate media as specified by a local agency.



STORMWATER HARVESTING

Using PICP System as a Storage Reservoir

Water harvesting utilizes a free resource to reduce municipal water supply costs, while complying with regional stormwater management guidelines.

In southern climates, a **no infiltration** system (complete with liner) can be used as the long term storage reservoir, with the water being used for irrigation, washing, or other non-potable applications. An integrated control system, which include water harvesting information is typically used to operate these harvesting systems. In addition, where the PICP is also serving a stormwater management function, it is recommended that an active control system be used to monitor weather forecast information and to automatically draw down the water volume to accommodate projected precipitation rates.

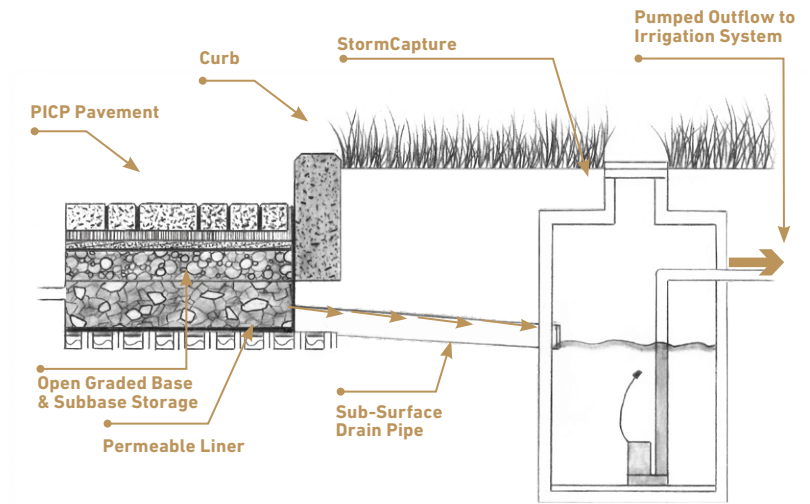

Water Harvesting Using PICP

PermeCapture™

In certain applications, combining the benefits of PICP with the high volume detention/retention capabilities of StormCapture® vaults provides solutions for challenging site conditions. Examples of potential applications for PermeCapture include: coastal areas or sites with high water tables; poor or limited aggregate availability; poor soils, shallow rock, or excavation challenges; sites requiring access for inspection & maintenance of retention/detention water, or sites where aggregate water storage is not recognized or credited. The need to maintain an aesthetic surface is another reason to utilize this type of system. PermeCapture vaults are H-20 rated, and include HydraPorts to allow water from the PICP system to drain into the storage chambers. When used as a retention system, treatment and harvesting technology can be incorporated into the PermeCapture system.

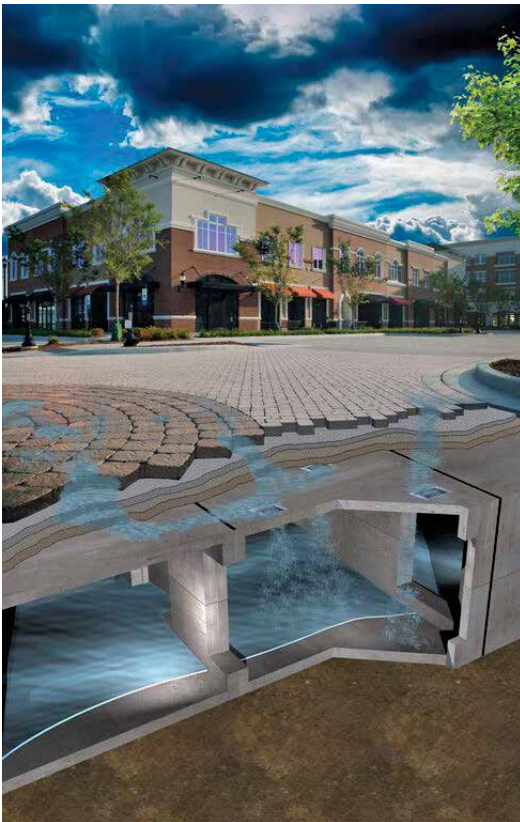

URBAN ENVIRONMENT

Reducing Deicing Salt Use

PICP systems perform very well in cold weather conditions. A recent study by the US Geological Survey in 2021 studied temperature profiles over a seven year period from different permeable pavement systems. Data showed that all types of permeable pavement developed favorable conditions to allow surface infiltration during winter rain and melting events with subsurface temperatures remaining above freezing, even when air temperatures were well below freezing. However, PICP was shown to be less susceptible to the effects of freezing air temperatures compared to both pervious concrete (PC) and porous asphalt (PA). The nature of PICP surface voids as well as the thermal mass of pavers may help insulate the aggregate reservoirs from surface temperature fluctuations much better than PC or PA.

A University of Toronto study in 2020 compared deicing operations impact on PICP compared to impervious asphalt surfaces. This research studied the winter safety benefits of permeable pavement and the use of deicing road salts that potentially harming waterways and biological systems. The researchers found that PICP can attenuate and buffer the release of salt to the environment, and that



PICP surfaces can be treated with lower application rates of road salts. The study confirmed the general view that PICP eliminates the potential black ice formation from standing water re-freezing.

Rather than use de-icing salts or sand, an alternative is to use the same ASTM #8 or #9 chip as used in the paver joints. Because permeable pavers are made with high quality concrete, snow can be plowed or shoveled without the need for special blades or equipment.

Sources: Danz, et. Al, Subsurface Temperature Properties for Three Types of Permeable Pavements in Cold Weather Climates and Implications for Deicer Reduction, 2021, US Geological Survey

Drake, et. Al, De-icing Operations for Permeable Interlocking Concrete Pavements, 2020, University of Toronto

Mitigating Urban Heat Island

The “heat island” effect impacts urban areas that have systematically used up existing natural ground cover by replacing them with buildings, parking lots and paved streets. The resulting lack of parkland and trees results in higher overall temperatures in these microclimates. In turn, these temperatures place a higher demand on energy, produce more pollution and greenhouse gas emissions, and clearly create quality of life issues for all those living in such environments.

One strategy to mitigate the heat island effect is to use high reflectance, light-colored paving materials. Solar Reflectance (SR) or albedo, is the percentage of solar energy reflected by a surface. Most existing studies on cool pavements have focused on increasing the solar reflectance which can reduce pavement and even subsurface temperatures. The LEED rating systems require light colored pavers to have an initial SR of ≥ 0.33 for potential credit. Belgard has a large offering of colors that can contribute to heat island mitigation strategies.

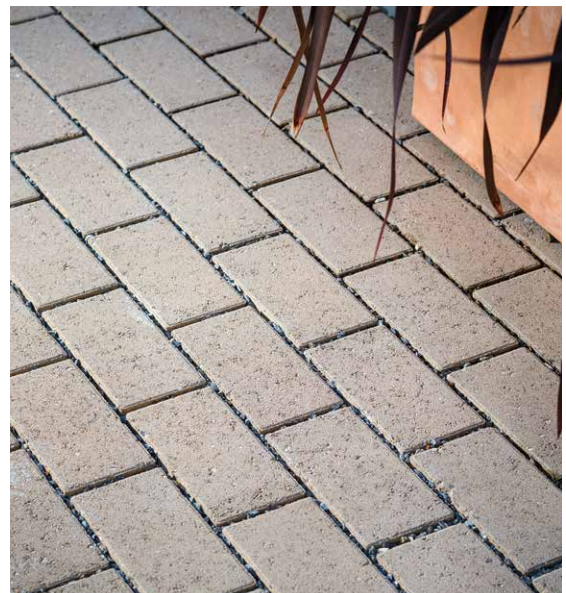

OPTIMIZING LAND USE

Increased Value & Safety

In conventional stormwater drainage designs, detention or retention ponds can consume a large portion of the site. These ponds have limited alternative applications (assuming the pond dries out sufficiently for the intended alternative use) and reduce the income generating footprint of the site.

PICP combine the parking and drive lanes with the retention or detention footprint, therein allowing the lands that would otherwise be consumed by the pond to be transformed into continuous use green space, recreational areas, or even reclaimed for increased development.

Examples exist where the use of PICP allowed for the preservation of wooded/ecological areas that would have otherwise been cleared for, or impacted by, the stormwater detention or retention systems.

In other commercial developments or subdivisions, additional building lots were added, with the revenue of the additional building or house exceeding any increased capital cost of the PICP system. In high density developments, more parking spots were available using PICP, and therefore more units were added to the high rise building. One developer in a particularly tight ocean front development referred to the additional parking stalls achieved by PICP as "million dollar lots" as he was able to add a one million dollar condo for each additional parking spot.

With the water detention/retention facility located below ground, we also eliminate public safety concerns associated with the accidental drowning of children and do not provide breeding grounds for insects that transmit diseases like West Nile Virus.

Note: Images courtesy of North Carolina Department of Environment and Natural Resources.

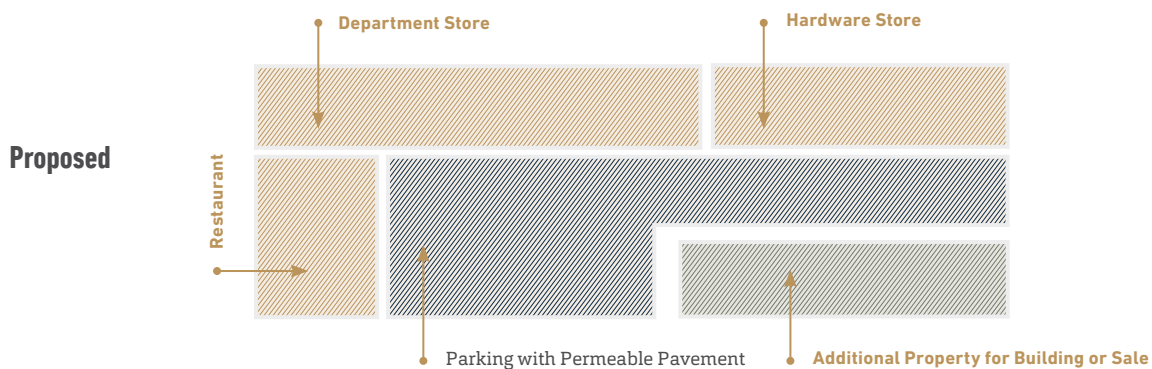
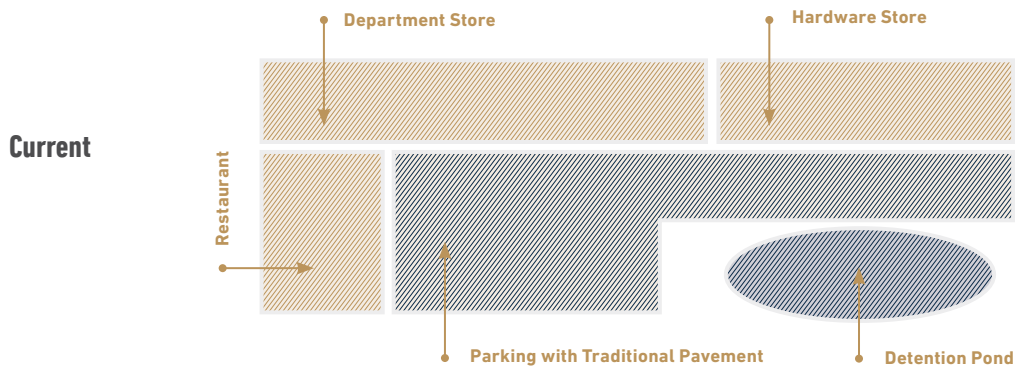

SWM PAVE



SWM Pave by Belgard Commercial

SWM Pave by Belgard Commercial is an Engineered System providing a 5-in-1 stormwater management solution that combines a long-lasting, heavy duty driving surface with these stormwater management functions: collection, water quality, conveyance, and storage. Belgard Commercial’s collaborative design process assists design professionals (civil engineers, architects, landscape architects) and project owners from concept through completion. With a clear understanding of the project goals, our end-to-end project support from design to installation to maintenance can optimize the project site and can reduce cost, reduce environmental impact, and exceed your site development goals.

SWM Pave by Belgard Commercial was developed to provide a green infrastructure solution and play a role in restoring the vital ecosystem. Our permeable pavers offer robust engineered systems to address both water quality and storage requirements, plus a heavy duty driving surface. These systems can be used in any area where an impervious surface is anticipated.

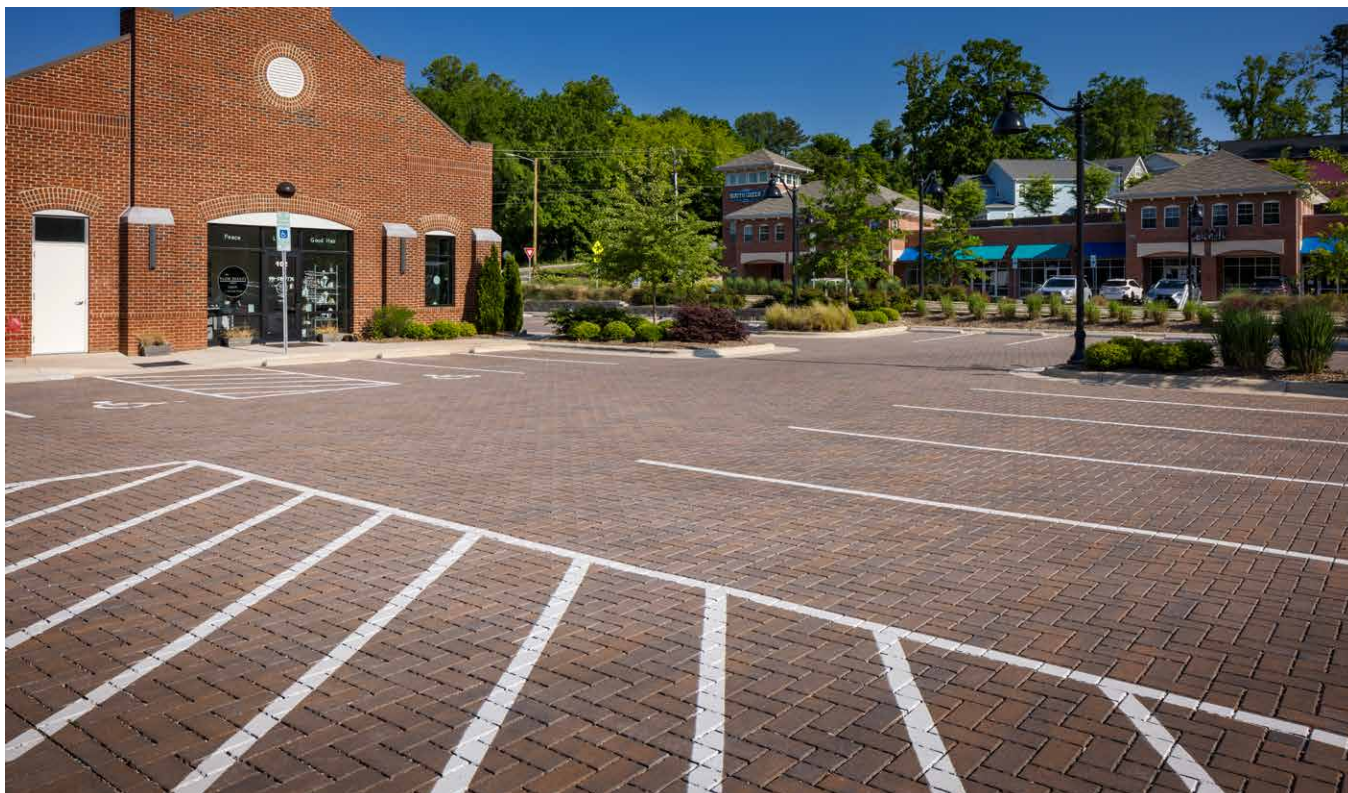
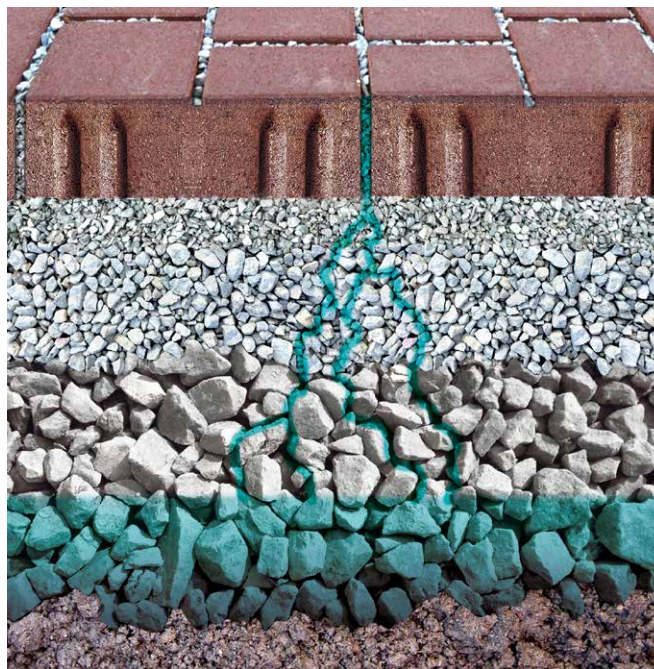

Our 3-Phased Approach Includes:

1. DESIGN

- Regulatory Assistance
- Paver System Design Services
- Construction Details
- Guide Specifications
- Cost Estimating
- Life-Cycle Cost Analysis

2. CONSTRUCT

- Contractor Support
- Constructability Reviews
- Network of Authorized Contractors
- Installation Guides
- Installation Checklists

3. MAINTAIN

- Infiltration Testing
- Inspection Checklists
- O & M Guides
- Maintenance Support

Sample project: Houston, TX

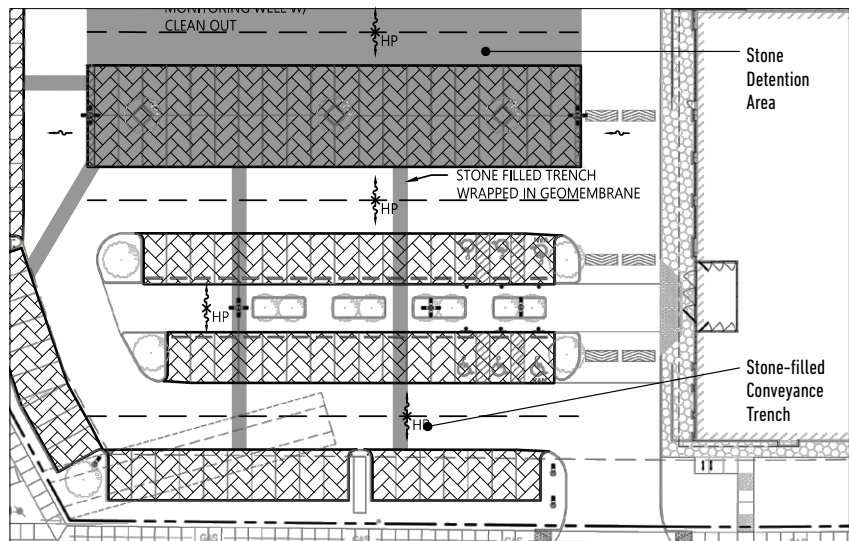

Our Three-Phased Approach

Our comprehensive Three-Phased Approach provides a step-by-step process working closely with the project team on design, construction, and maintenance.

The first phase in the SWM Pave process is Design. In this phase we provide regulatory assistance, paver design services, construction details, project specification writing assistance, cost estimating, and life-cycle cost analysis.

The second phase in the SWM Pave process is Construction. Construction details are critical to the project's success and long-term performance. In this phase we provide contractor support, constructability reviews, a network of authorized contractors, installation guides and checklist which all play key roles in the long-term performance of the SWM Pave system.

The third phase is maintenance and is crucial in protecting the integrity and performance of any stormwater management system. Maintenance includes Infiltration testing, inspection checklist, O & M Guides, and maintenance support which defines routine and restorative measures, plus highlights maintenance equipment, procedures for maintaining infiltration, seasonal maintenance schedules and winter maintenance and deicing.

The SWM Pave by Belgard Commercial system offers tremendous value providing both a complete stormwater management system and fully functional driving surface. The SWM Pave by Belgard Commercial team works side-by-side with the project team from concept through continuing maintenance. For more information contact your Belgard Commercial representative. Our team is always eager to explain the SWM Pave by Belgard Commercial process and how we can help with construction details, project design, obtaining regulatory approvals, & more.



03

Segmental Retaining Walls (SRW)

Backed by years of experience and a national network of manufacturing facilities, Belgard® offers technical expertise and SRW products to meet the site challenges of projects that range from light commercial to the most challenging of site conditions. From functional to aesthetic wall systems, Belgard offers a variety of options.

Types of Retaining Wall Construction.....	30
Segmental Retaining Wall Best Practices Guide.....	32
How Segmental Retaining Walls Help in Land Development	34
Examples of Site Utilization.....	34





TYPES OF RETAINING WALL CONSTRUCTION

Gravity Wall Construction

A gravity retaining wall relies on the weight and batter of the SRW units to resist the soil forces exerted on the wall. Geogrid soil reinforcement is not used with gravity walls. The allowable heights of gravity retaining walls are typically limited to 2 to 3 times the front-to-back depth of the SRW facing unit.

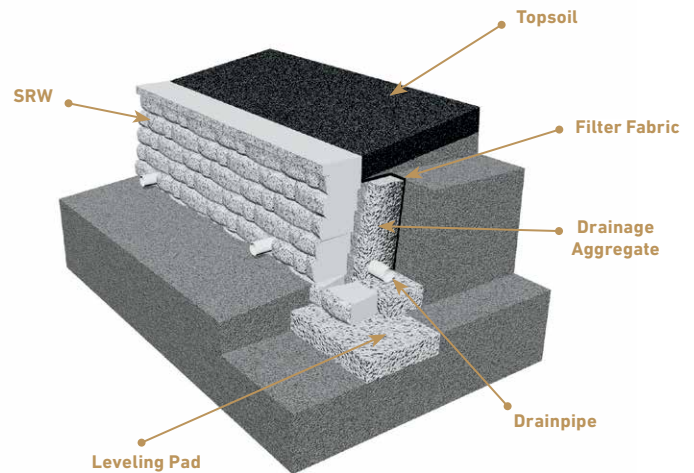

Geosynthetic-Reinforced Retaining Wall

Geosynthetic reinforced walls use soil reinforcement layers, typically geogrids, to stabilize the soil behind the SRW facing, creating a coherent mass large enough to resist the soil forces acting on the wall system. The SRW facing unit, the geosynthetic reinforcement and the reinforced soil together then form the retaining wall system. To resist more load, the reinforcement layers are lengthened and/or strengthened to provide the required resistance. Thus, reinforced wall systems can be designed for much taller earth retention heights and loading conditions than conventional gravity walls. Reinforced retaining walls should be designed by a qualified engineer and constructed by experienced contractors.

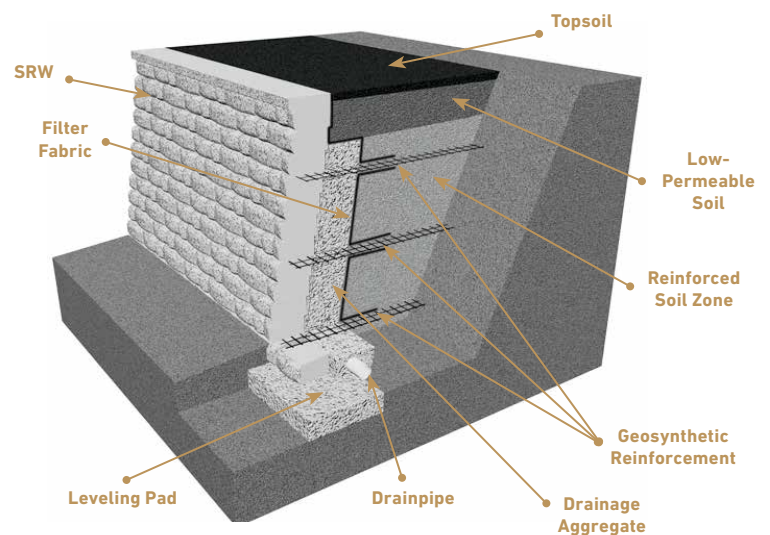

Structural Backfill

Occasionally in retaining wall applications, enough space does not exist behind the face units to allow excavation for placement of geosynthetic reinforcement. For these instances, an SRW can still be designed using specialized structural backfill to increase the depth and mass of the facing system. Using specialized structural backfill eliminates the use of geosynthetic reinforcement. The structural backfill also acts as the drainage zone for the retaining wall. This design approach also requires substantially less excavation than is required for geosynthetic reinforced retaining walls. Retaining walls using structural backfill should be designed by a qualified engineer and built by experienced contractors. Structural backfill is also referred to as “no-fines concrete”, “stabilized aggregate”, and “Anchorplex System®”.

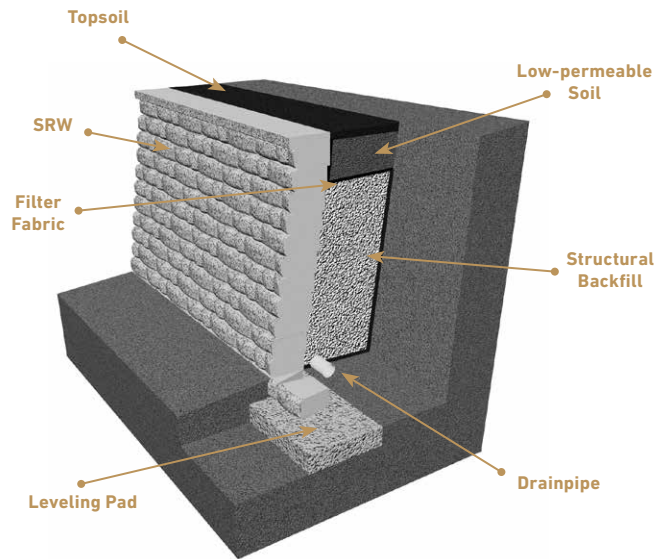

Geosynthetic Reinforced Soil – Integrated Bridge System (GRS-IBS)

The Federal Highway Administration has developed GRS-IBS technology as an innovative and cost-effective bridge system that is an alternate option to conventional bridge construction. The system uses closely spaced geosynthetic reinforcement layers and compacted aggregate to directly support the bridge superstructure. Due to the simplicity of design, construction speed, use of readily available materials and the elimination of deep foundations, the GRS-IBS method can reduce costs by 25-60% compared to conventional methods. GRS-IBS should be designed by a qualified engineer and constructed by experienced contractors.

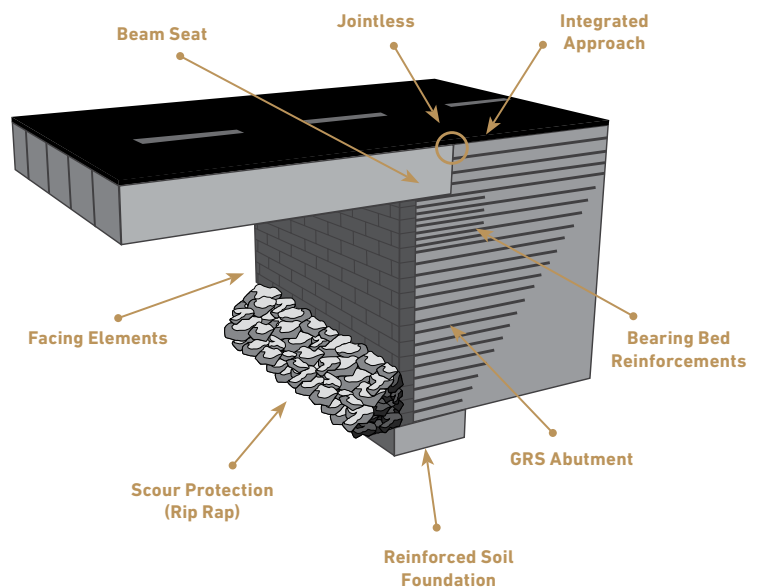

SEGMENTAL RETAINING WALL BEST PRACTICES GUIDE

The National Concrete Masonry Association (NCMA), the trade organization representing masonry and segmental retaining wall (SRW) producers and affiliates, has developed an SRW Best Practices Guide.

The Guide provides educational materials in support of NCMA's Zero Wall Failures Initiative. This initiative is "an industry-wide program to educate owners, designers, site civil engineers, geotechnical engineers, and installers of SRW systems on the industry's recommended best practices and to promote a philosophy that strives for ensuring successful wall performance." Using the Guide will help reduce poor retaining wall performance in addition to reducing liability of the involved design professionals by presenting information and guidelines regarding standards of practice. Some key suggestions from the Guide include:

- **Follow provided guidelines for optimum project organization that define roles and responsibilities for the various parties involved in retaining wall design and construction.**
- **Retaining wall design should be done during the design phase of the project by a design professional working directly for the project owner or owner's representative and not be procured by the retaining wall contractor during the construction phase.**
- **Global and Compound Stability must be evaluated.**
- **The SRW components consisting of the face unit, soil reinforcement, and soil, must meet basic industry standards.**
- **Taller walls require special considerations including tighter standards for the reinforced soil.**

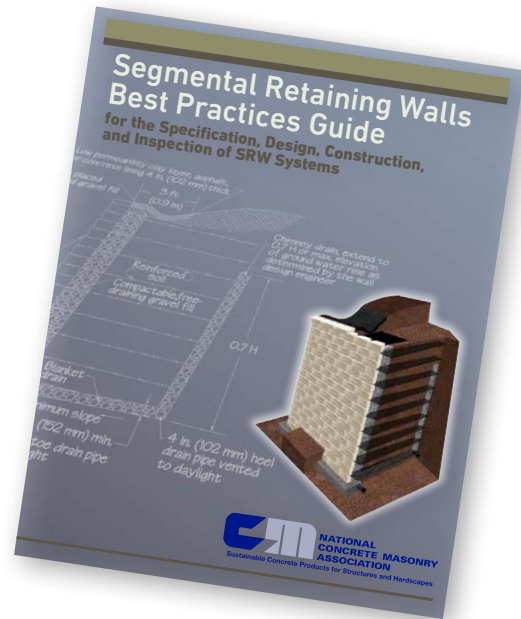

Planning Considerations

The SRW design should be performed during the design phase of the project with the SRW designer as part of the design team. At the onset of the project, the SRW design engineer and site civil engineer should meet with the property owner to understand how the site will be used, project timeline and aesthetic objectives. Everyone on the team should also have an understanding of any special considerations, including local codes or ordinances, unusual site conditions and project relation to existing structures or utilities. Other issues that will impact design include existing site drainage and topography, surface water, soil characteristics, property lines, and proposed locations of structures, roads and utilities. The owner or site civil engineer should contract with a geotechnical engineer to obtain a report on soil characteristics, groundwater conditions, applicable seismic coefficients and applicable foundation remediation needs. Site access constraints may also exist that will impact construction or staging and should be discussed in the planning phase.

Choosing SRW Units

Segmental retaining wall units are available in a myriad of sizes, shapes, textures and colors. The minimum requirements for SRW units are covered in ASTM C1372, Standard Specification for Dry-Cast Segmental Retaining Wall Units. As with any product standard, these minimum requirements are appropriate for many, but not all, SRW applications. In areas that require extreme freeze/thaw durability, higher performance products may be required.

Building Tall Walls

Walls in excess of 10 feet require better soils, more rigorous attention to quality control, closer scrutiny to potential settlement, greater attention to compaction efforts during construction and careful attention to detailing. Project designer professionals must pay careful attention to site conditions well beyond the location of the SRW system. In addition, layout considerations, such as the wall batter and geosynthetic reinforcement lengths, become more significant. Other considerations include site geometry, existing or new structures above or below the wall, property boundaries and the extent of required excavation.

Choosing Geosynthetic Reinforcement

The full evaluation of geosynthetic reinforcement materials is very important, yet very complex. Fortunately, a third-party review system is already in place to verify the strength properties and QC standards of reinforcement materials through the National Transportation Product Evaluation Program (NTPEP). Therefore, a best practice is to only use geosynthetic reinforcements with a current NTPEP report.

Reinforced Fill Gradation For Tall Walls

SIEVE SIZE	PERCENT PASSING	
	WALLS BETWEEN 10-20'	WALLS > 20'
1 in. (24 mm)	100	100
No. 4	20-100	20-100
No. 40	0-60	0-60
No. 200	0-35, Pl < 6	0-15, Pl < 6

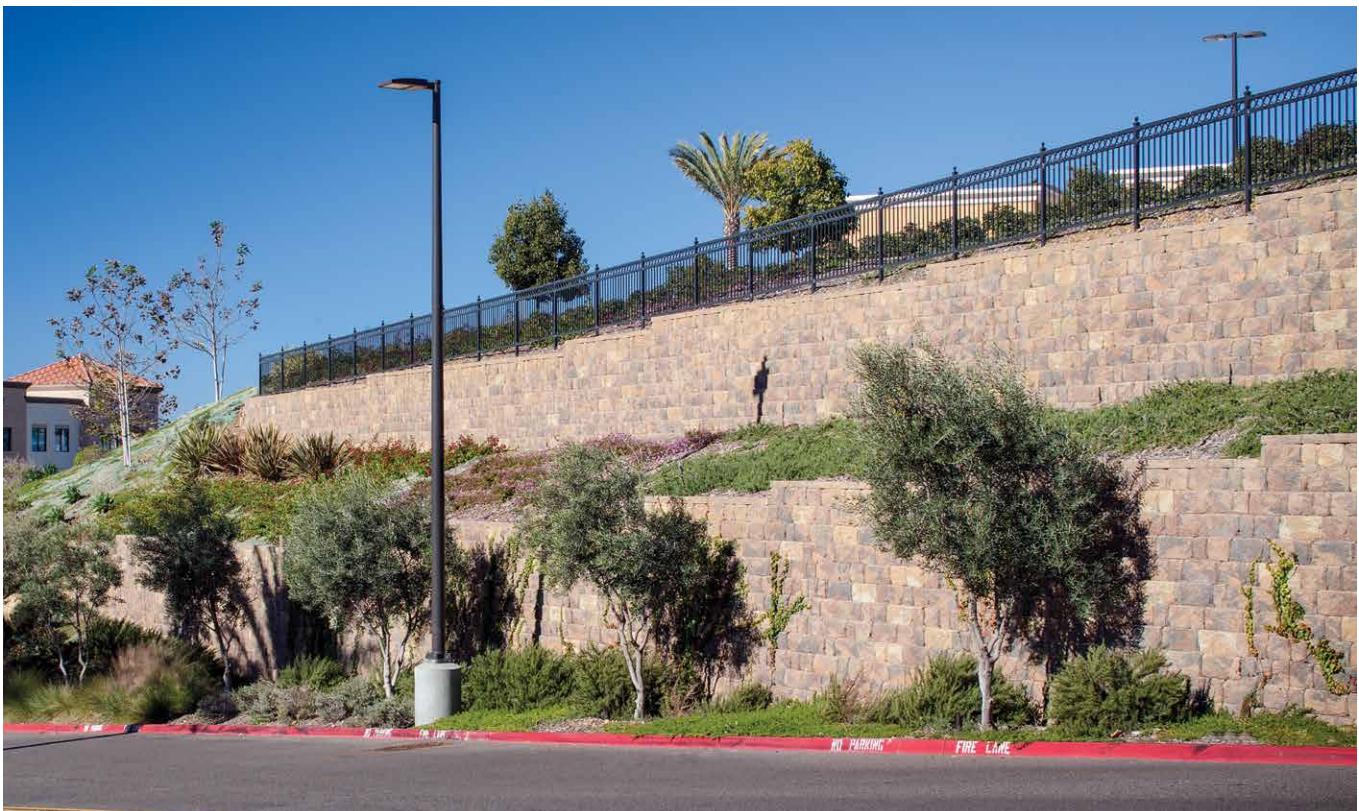

HOW SEGMENTAL RETAINING WALLS HELP IN LAND DEVELOPMENT

Proper Site Planning

Proper site planning can save significant time and money. Segmental retaining walls can convert a slope that uses horizontal space to a vertical grade change creating more useable and valuable land space. Segmental retaining walls should be considered for:

- **Cost effectiveness**
- **Performance**
- **Aesthetics**
- **Versatility**
- **Speed of Construction**
- **Durability**
- **Environmentally Friendly**



EXAMPLES OF SITE UTILIZATION:

Slope Stabilization and Erosion Control

Soil stabilization is key to maintaining the integrity of the project site. By increasing the stability of the soil, you can increase your useable space on any project site and help prevent unnecessary erosion.

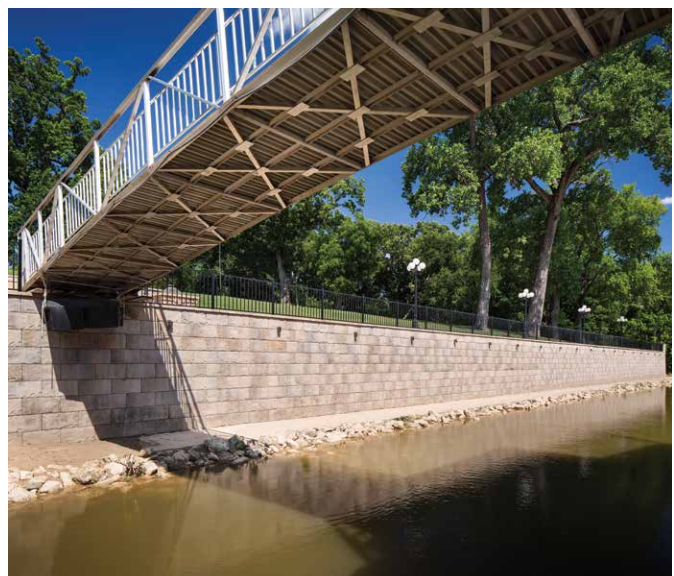

Water Management

The most significant slopes at most typical land development projects are around the project perimeter, along interior water courses, around stormwater management ponds and wetland boundaries and between buildings. Segmental retaining walls help minimize the loss of valuable real estate at these locations by minimizing developmental impacts of stormwater ponds footprint and encroachments into wetland.



Terraced Walls

Terracing walls creates horizontal spaces that may improve landscape maintenance by eliminating steeper slopes that are hard to vegetate and maintain. Terraces can also provide valuable space for utilization of parking, patios and landscape.

- **Create more useable space by replacing an unusable slope with flat terrain**
- **Create a variety of levels on the site, such as terraced gardens and outdoor seating areas**



04

Rooftop Plaza Pavers & Accessories

Plaza decks on rooftops and terraces provide practical solutions for optimizing space and building decks over sloping, difficult or uneven surfaces. Whether the plaza design is simple or complex, our mission is to assist the architect, building owner and contractor in producing a plaza surface to achieve the look you have envisioned.

Rooftop Paver Layout Service

During the bid phase of a project, Belgard Commercial can provide a rough component count based on square footage. This will include paver counts and pedestal counts. Solutions to address wind uplift are also available. Once the project is awarded, a detailed layout (example 1) can be created showing more precise pedestal counts, heights and locations. This detailed layout takes approximately 5-7 business days to complete.

Example 1

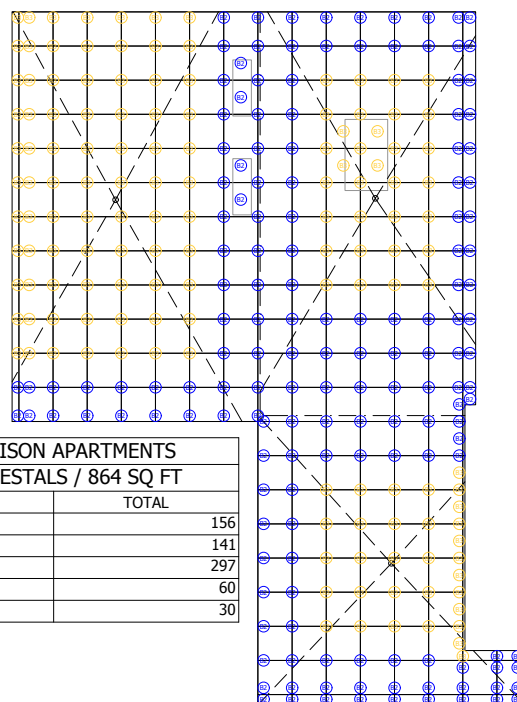

DESIGN CONSIDERATIONS	INFORMATION NEEDED FOR A DETAILED LAYOUT
Bracing for High Wind Applications	Paver type and size
Safety backing for porcelain pavers	Deck plan
Pedestal and truss options, placement layout	Deck slope
Integrated site furnishings	Drain locations
Roof assembly and membrane protection	Threshold/starting height

PEDESTAL SELECTION

Level System

The Level System is used for a dead level paver surface. This system allows for installation of a level paver surface over various sloping substrates. This system is for conventional or IRMA Roof Assembly and for pedestrian use only.

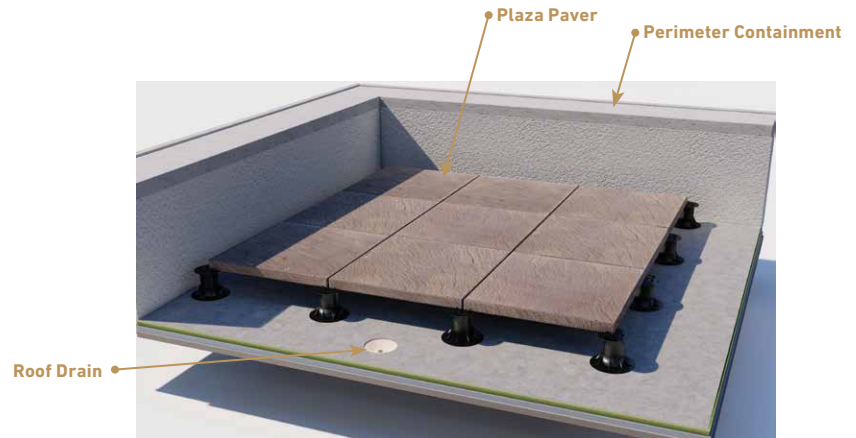

Sloped System

The Sloped System can be used when a dead level paver surface is not necessary. Pedestals are loose-laid and not attached to the roof assembly. If insulation is used, the insulation must have a minimum 40 psi compressive strength. Otherwise, a protection/recovery board is required.

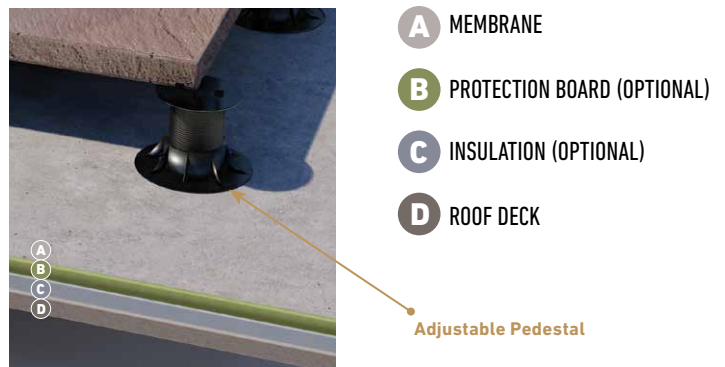

Pedestal Selection/ Elevation

Installation requirements vary for each individual project site. Paver size, pattern, grid layout, starting point and finished deck surface elevation should be shown on shop drawings which have been approved by the designer, installing contractor and owner. Measurements from the construction site should be used for final pedestal selection and purchasing. The Finish Deck Surface Elevation is determined at the door threshold. The shortest pedestals are usually at the door threshold and the tallest are at the roof drains. To obtain pedestal height, subtract paver thickness from the Finish Deck Surface Elevation.

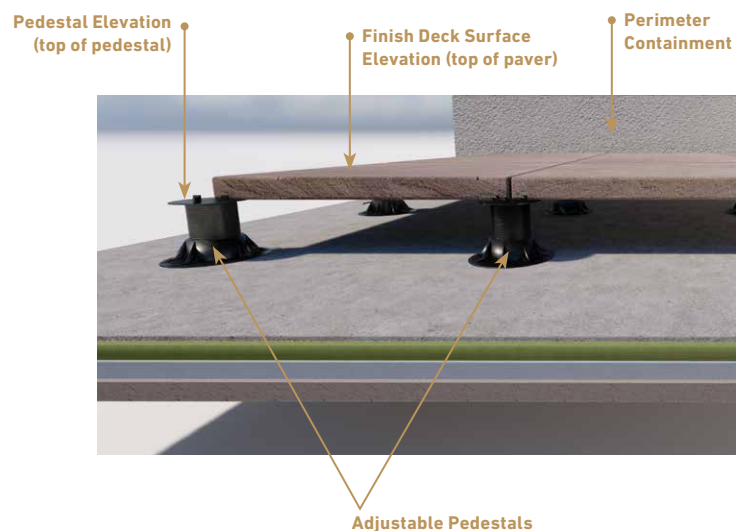





IPE WOOD & CLASSIC PLAZA SLAB

PROFESSIONAL SUPPORT



ENVIRONMENTAL SOLUTIONS

Belgard consultants can work with your team to develop the best PICP system design or retaining wall configuration to control runoff volume and discharge rates, improve the quality of local groundwater, reduce or prevent downstream impacts, and minimize the land consumed for stormwater management.



SITE PLANNING

The experts at Belgard can help you optimize your site in a number of ways—whether you're looking for creative ways to define public spaces, manage or harvest stormwater, or increase the useable space for development.



ENGINEERING SERVICES

Our team of design consultants can help address both aesthetic and engineering design concerns, material quantity estimates and permit ready plans.



CAD FILES

For your convenience, Belgard offers a constantly expanding library of easy-to-download CAD files of our products and patterns.



CONTINUING EDUCATION

Belgard offers a variety of ongoing educational programs for our industry partners, including Lunch & Learns, online CEU courses, and our Belgard University training program.



Oldcastle APG
A CRH COMPANY

400 Perimeter Center Terrace, Suite 1000
Atlanta, GA 30346
Ph: 844-495-8210



[BELGARDCOMMERCIAL.COM](https://www.belgardcommercial.com)